

IMPORTANT NOTE - SUITABLY SIZED LIFTING SHACKLES SHOULD BE USED THROUGH LIFTING EYES WITH A MINIMUM SLING LENGTH OF 2500[98.4].

NOTE : 1.5M OF CLEAR SPACE SHOULD BE LEFT AROUND THE LOADBANK FOR COOL AIR INLET AND MAINTENANCE ACCESS. AT LEAST 5M SHOULD BE LEFT CLEAR BETWEEN HOT AIR OUTLET AND ANY SURFACE

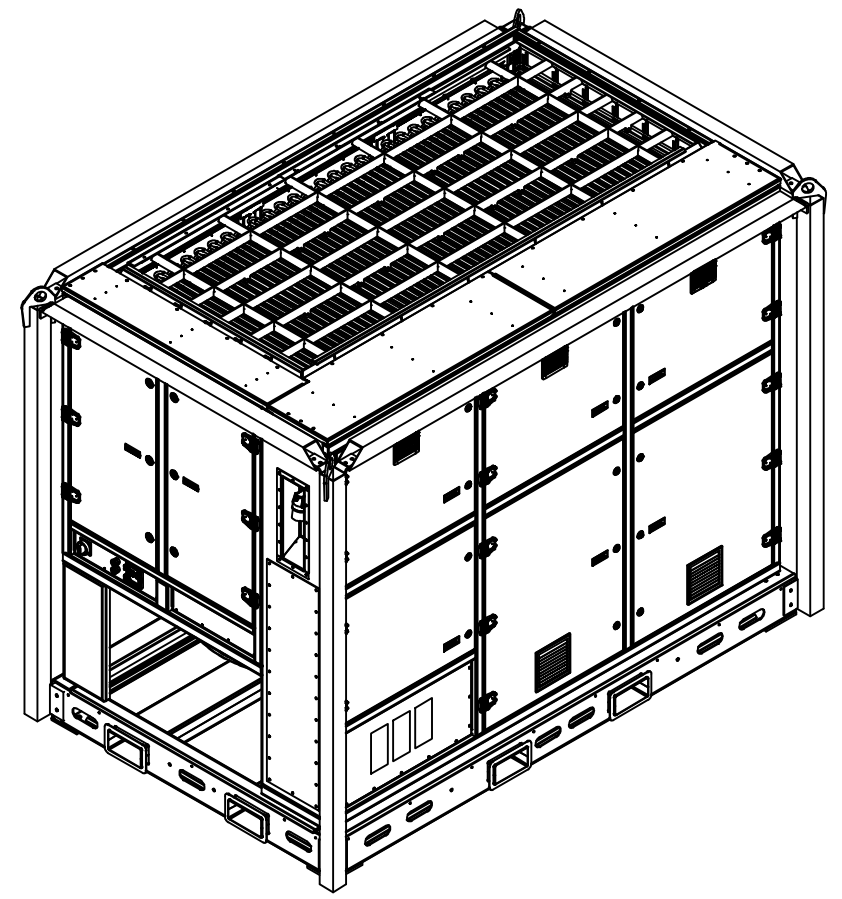

MAX WEIGHT - 2400 KG / 5291LBS



NJ Froment & Co Ltd  
Easton on the Hill  
STAMFORD - PE9 3NP - UK  
Tel: +44 (0) 1780 480033  
avtronpower.com

© NJ Froment & Co. Ltd. This document may not be copied or disclosed in whole or part without prior written authority.

Drawn - RPM	Date - 13/12/2021
Approved -	Date -
Checked -	Date -

3220	GENERAL ARRANGEMENT - MOVABLE
Scale. NTS	1st Angle Projection
Dims. mm	

CAD Code. 3220
Part Number. N/A
Drg No. GAM3220A01
Sheet 1 OF 1